



# P1902 Installation Manual

Precision Lighting Controller

P1902-JRev. 1.0

A decorative graphic consisting of several overlapping, semi-transparent blue and grey rectangular blocks arranged in a perspective view. The year "2010" is printed in a large, bold, red font on the right side of the graphic.

2010



**NOTE: Inspect the Profile P1902 System components prior to installation for any damage which may have occurred during shipping. Report any damage found to Profile Systems, LLC immediately.**

Installation of the Profile Systems P1902 Precision Lighting Controller may expose an individual to potentially unsafe conditions. Proper procedures must be carefully followed to avoid electrical shock, unsafe voltages, or improper operation that may cause personal injury and/or damage to property.

Installation of the Profile Systems P1902 Precision Lighting Controller should only be performed by qualified electrical contractors. They should be properly licensed to perform work in the municipality, county, and state where the installation of equipment will occur. **Installation practices should follow recommendations and procedures as determined by the original equipment manufacturer(s) and should adhere to the application and use of the equipment as intended by the original equipment manufacturer(s).**

- 1) Mount the P1902 controller using the 4 outermost enclosure holes (**see P1902 System Wiring Overview diagram on page 2**) in a manner that satisfies the following criteria:
  - a. Unit is to be mounted in a plumb and level fashion using appropriate anchoring hardware near the existing lighting electrical panel and/or contactors such that high voltage wiring and conduit requirements are minimized.
  - b. Unit is to be mounted away from high traffic or commonly used work spaces.
  - c. Antenna bracket for wireless communications is to be mounted parallel to the floor/ceiling and above the P1902 controller using appropriate anchoring hardware. At no time should the antenna or its mounting be connected to earth ground. Weak communications signal may require the antenna to be mounted outside the facility (**see P1902 System Wiring Overview diagram on page 2**).
- 2) Connect power to the P1902 controller. **Make sure to use a 120VAC or 240VAC input power source from an independent breaker whenever possible.**
- 3) Call Profile Systems Customer Support at 1-800-898-5483 to begin the commissioning process (**see "Appendix B - Commissioning Procedure"**) prior to completing the installation.
- 4) Circuits of specified controlled loads (i.e. exterior lighting) will be energized by wiring the existing contactors to the proper positions on the termination strip of the P1900 System unit. Refer to detailed wiring diagram #1a. For example, exterior lighting may be connected as follows when required:

- Circuit 1 (K1): Parking Lot Lights
- Circuit 2 (K2): Building Lights & Signage
- Circuit 3 (K3): Spare
- Circuit 4 (K4): Spare

The normally closed dry contacts of relays K1 thru K4 can be used with various loads. (Refer to detailed wiring diagram #1b) Contacts are rated as follows:

- 120 VAC @ 10 amps
- 240 VAC @ 5 amps
- 277 VAC @ 3 amps

**NOTE: Ensure the correct loads/circuits are controlled by the P1900 System unit per site requirements.**

- 5) Call Profile Systems Customer Support at 1-800-898-5483 to complete the commissioning procedure (see "P1902 System Commissioning Procedure").

# APPENDIX A - INSTALLATION DIAGRAMS

## P1902 System Wiring Overview

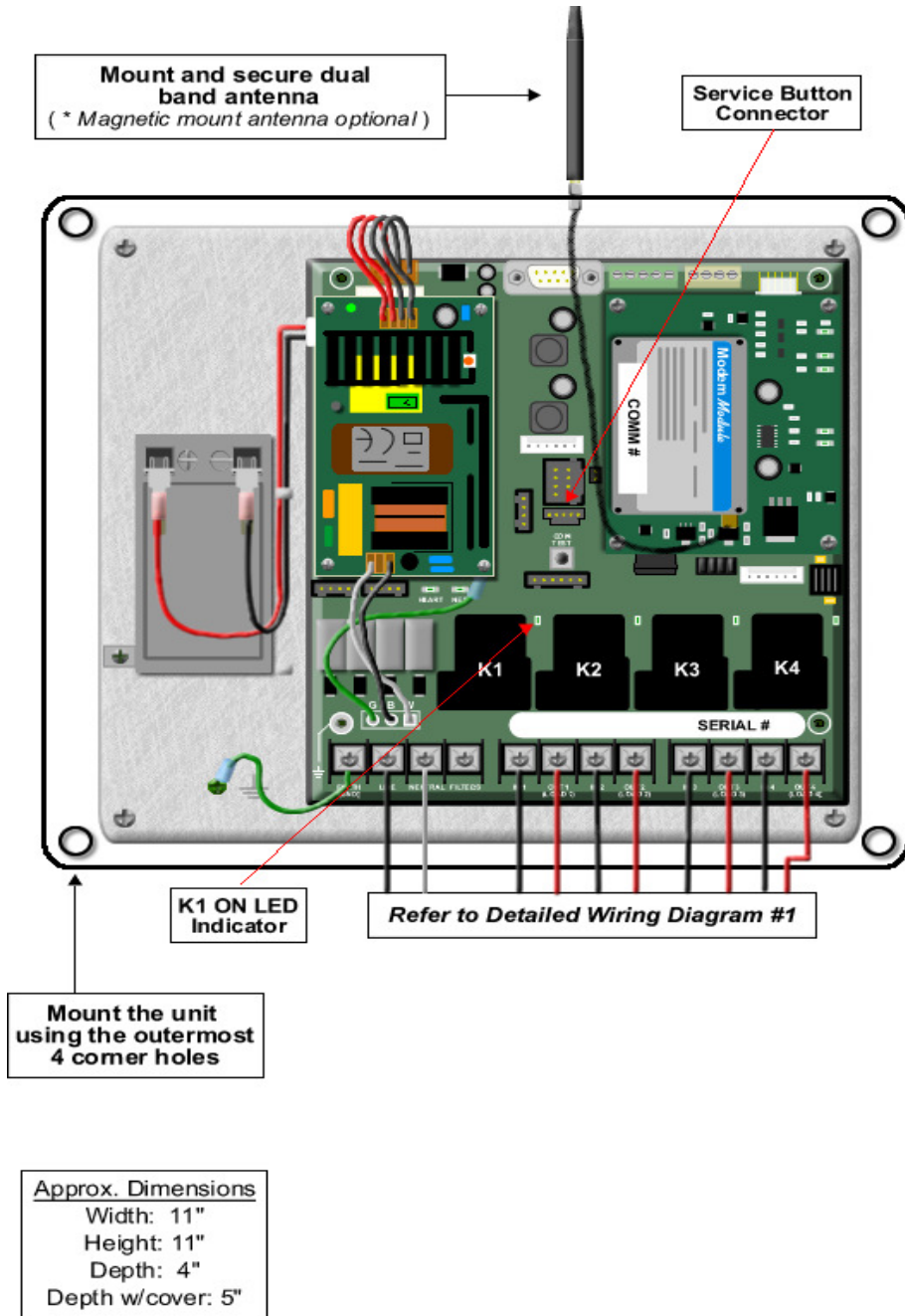

Revision v2.1

# Detailed Wiring Diagram #1a

(Sample Wiring Diagram)

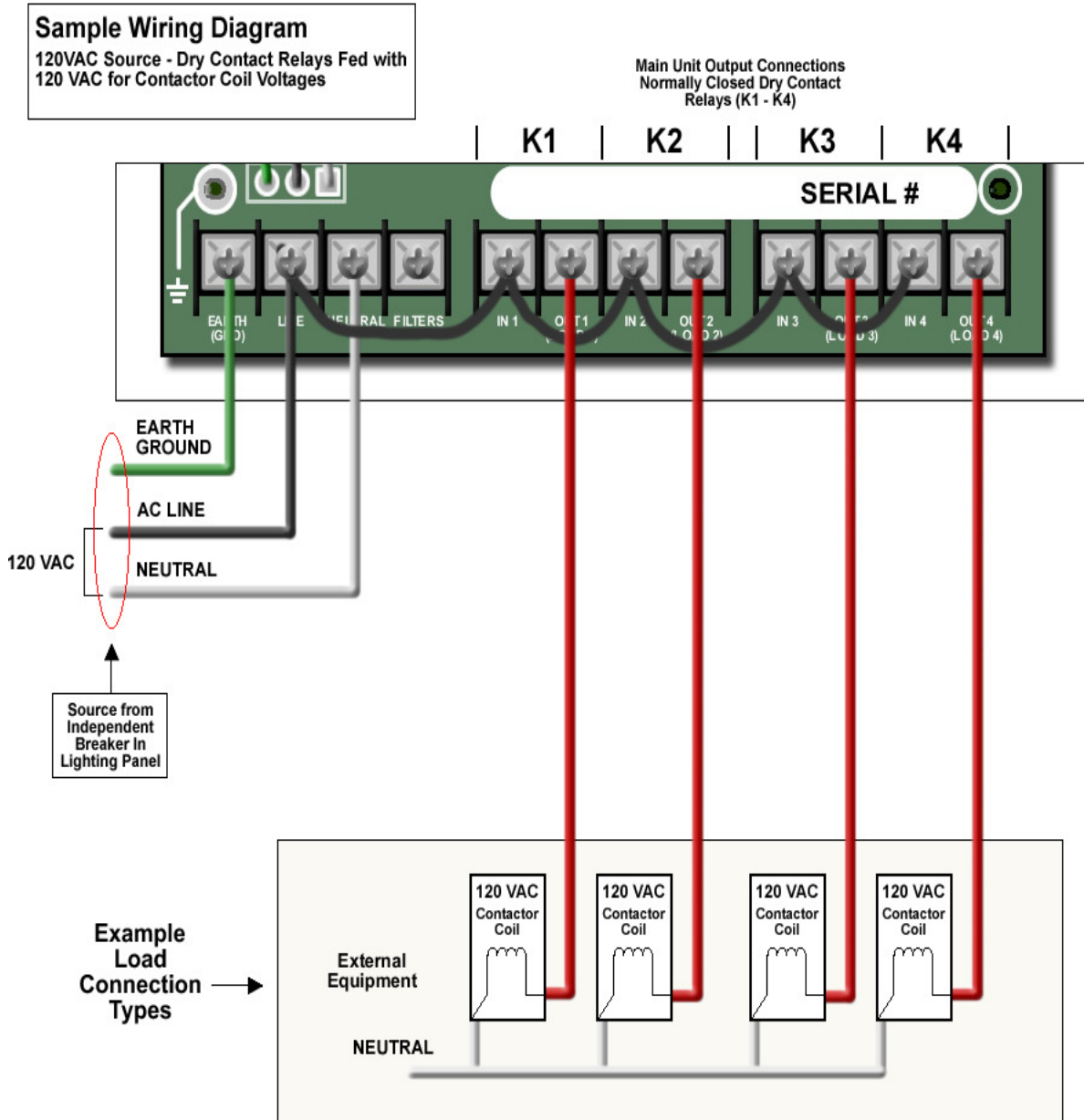

Revision v1.0

# Detailed Wiring Diagram #1b

(Sample Wiring Diagram)

## Sample Wiring Diagram

120VAC Source - Dry Contact Relays Fed with Various Voltages for Different Contactor Coil Voltages

Main Unit Output Connections  
Normally Closed Dry Contact  
Relays (K1 - K4)

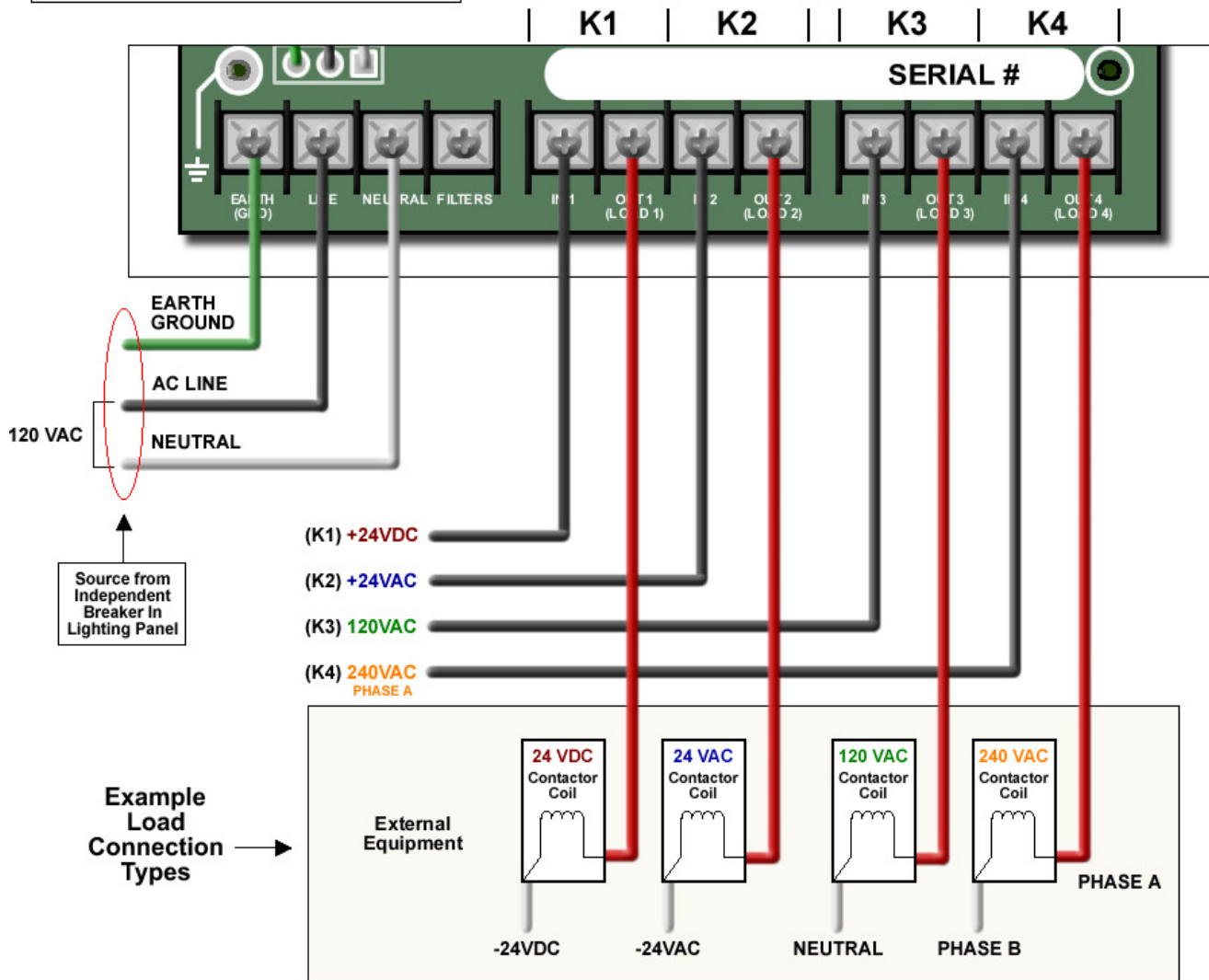

\* Make sure to use appropriate wire gauge when connecting to external equipment.

Revision v1.0

# **APPENDIX B – COMMISSIONING PROCEDURE**

**The following procedural steps are necessary to properly commission a Profile P1900 System installation and verify the operational status of the system. Failure to complete ANY of these steps during installation will result in a non-commissioned P1900 System.**

## **Step 1:**

After mounting and powering the P1900 series controller *and* antenna, locate the LED labeled “NET” on the main controller board (see figure B-1). Note the status of this LED (i.e., lit, not lit, or blinking).

## **Step 2:**

Call Profile Customer/Technical Support at 1-800-898-5483. Indicate that you are calling for initial system commissioning verification and provide the Customer Support Representative (CSR) with your name, your company, the installation location, the serial number (see figure B-1) of the P1902 controller, and the “NET” LED status.

## **Step 3:**

The Profile CSR will proceed through a series of system checks and tests to verify the P1902 controller is communicating and functioning properly.

## **Step 4:**

Upon successful completion of steps 1 through 3, the Profile CSR will endorse the P1902 controller as commissioned.

**NOTE:** System verification is a vital step in the commissioning process. The installing contractor needs to allocate time at the end of the installation for this process. Unless instructed by Profile Systems, finalizing an installation prior to performing the verification process will leave the installer/contractor responsible for the cost to revisit the location and properly finish the commissioning process.

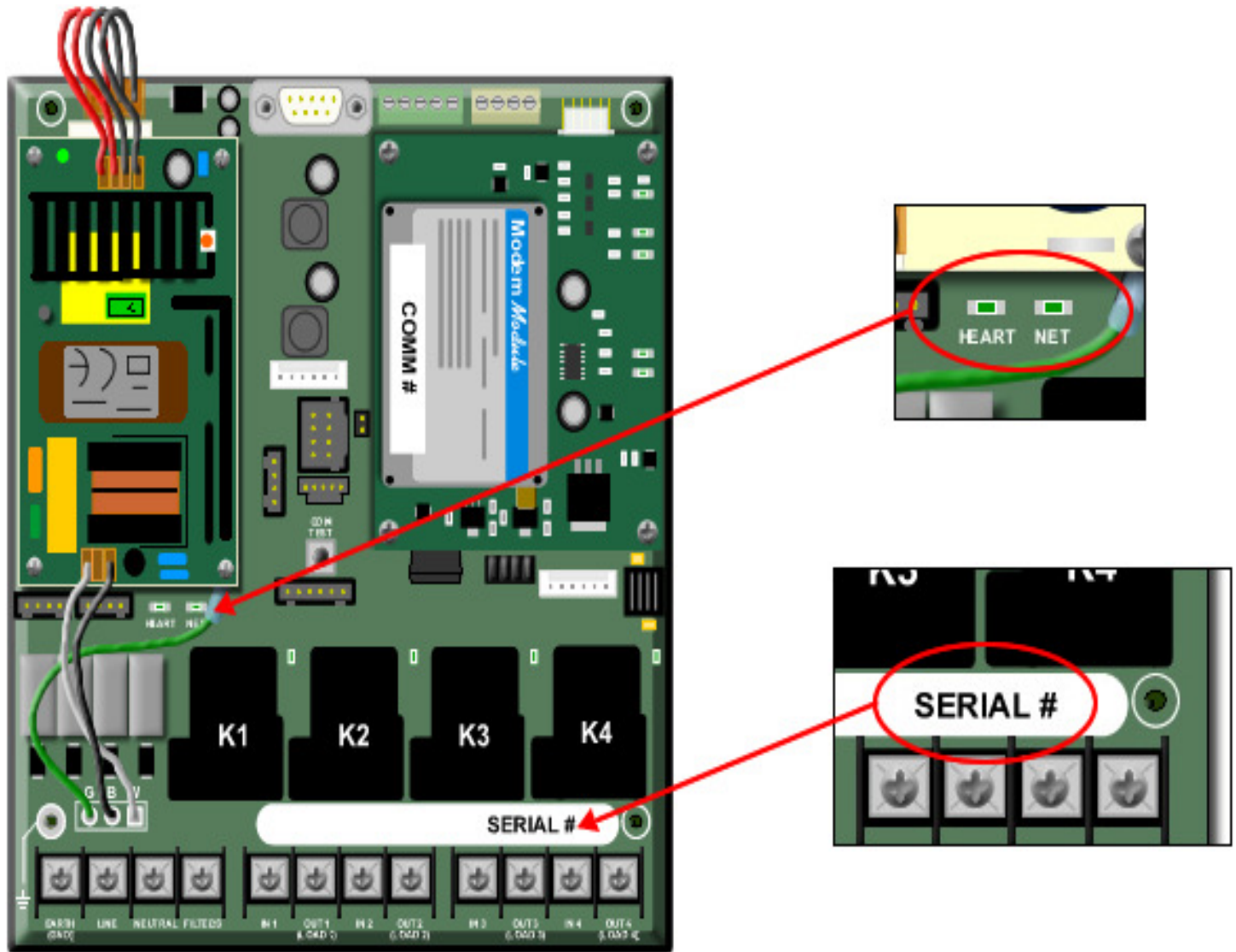

Figure B-1





## LIMITED WARRANTY

**Profile Systems, LLC, warrants to the original purchaser that its product, as originally supplied, is free from defects in materials and workmanship and will perform adequately under normal use and service, subject to the following conditions and limits:**

If within twelve (12) months from the date of original purchase, the product or any part thereof proves to be defective in normal use, then the product will be replaced or repaired at the option of Profile Systems, LLC, provided that such notice of such defect is given by the original purchaser to Profile Systems, LLC, within twelve (12) months from the original date of purchase.

Profile System, LLC's, obligation under this warranty is limited exclusively to replacing without charge or repairing without charge the product upon the return of the defective product to Profile Systems, LLC, offices in Merrillville, Indiana. Once, in Profile Systems, LLC's, sole opinion, it has been determined that the product has not been used in an inappropriate manner, as described in the Profile Systems, LLC, Installation Manual for P1900 series models or has not been subject to misuse, alteration, accident, damage during transit or delivery, or does not have an altered serial number, then warranty work will proceed. All decisions regarding the existence of defects in material or workmanship or other causes of failure shall be made by Profile Systems, LLC, and shall be binding upon the parties. Returns shall be made only upon the prior authorization and issuance of an RMA from Profile Systems, LLC. This warranty specifically does not apply to damage caused by lightning or excess power applied to the product.

**THE FOREGOING LIMITED WARRANTY IS EXPRESSLY MADE IN LIEU OF ANY AND ALL OTHER WARRANTIES EXPRESS OR IMPLIED INCLUDING WITHOUT LIMITATION ANY IMPLIED WARRANTY OF MERCHANTABILITY OR FITNESS FOR A PARTICULAR PURPOSE.** Profile Systems LLC's limited warranty shall not be enlarged or affected by and no liability or obligation shall arise from Profile Systems, LLC's rendering of technical or other advice, or service, in connection with its equipment or parts. Employees, agents, distributors, and sales representatives are not authorized to make warranties. Oral or written statements by them do not constitute warranties and shall not be relied upon. **REPLACEMENT OR REPAIR OF DEFECTIVE EQUIPMENT OR PARTS IS THE PURCHASER'S SOLE AND EXCLUSIVE REMEDY FOR CONTRACT, WARRANTY, NEGLIGENCE, TORT, OR STRICT LIABILITY CLAIMS FOR ANY LOSS, LIABILITY, DAMAGE OR EXPENSE ARISING FROM OR ALLEGED TO ARISE OUT OF THE DESIGN, MANUFACTURE, SALE, DELIVERY, OR USE OF SUCH PRODUCT, EQUIPMENT AND/OR PARTS. IN NO EVENT SHALL PROFILE SYSTEMS, LLC, BE AT LAW OR IN EQUITY, LIABLE FOR ANY SUCH LOSS, LIABILITY, DAMAGE OR EXPENSE IN AN AMOUNT IN EXCESS OF THE PURCHASE PRICE OF THE PRODUCT OR EQUIPMENT OR FROM LOSS OF USE, OR PROFITS, LOSS FROM BUSINESS INTERRUPTION, ATTORNEY'S FEES OR CONSEQUENTIAL, CONTINGENT, INCIDENTAL OR SPECIAL DAMAGES CAUSED OR ALLEGED TO BE CAUSED IN WHOLE OR IN PART BY THE NEGLIGENCE, TORT, STRICT LIABILITY, BREACH OF CONTRACT, BREACH OF WARRANTY OR OTHER BREACH OF DUTY OF PROFILE SYSTEMS, LLC.**

**THIS WARRANTY IS NON-TRANSFERABLE.**