



P1945 Installation Manual

Precision Energy Management System

P1945-J-DLC- Rev. 1.2

2010

INSTALLATION GUIDELINES

This **Scope of Work & Installation Guideline** outlines the specific responsibilities of subcontractor (“Subcontractor”) in the installation of specialized communications devices, lighting control, HVAC system control, and environmental monitoring equipment collectively referred to as the **Profile Systems P1900 Series System Unit**. It is expected that the Subcontractor will perform all duties to a professional standard, and will provide the necessary labor and non-P1900 Series System Units miscellaneous components and material to ensure a complete installation, even if such items are not specifically identified in this or other documentation.

- A) Subcontractor will furnish all labor, material (other than P1900 Series System Unit hardware components) and miscellaneous parts needed to install a fully operational P1900 Series System Unit. Subcontractor is responsible for all permits, licensing and inspections. Subcontractor must comply with all local, state and national codes, including, but not limited to, “Americans With Disabilities Act (ADA)” height requirements and the National Electrical Code (NEC).
- B) Before performing any work, the subcontractor will provide a Certificate of Insurance, as outlined in Exhibit C of the Subcontract Agreement, naming the following entities as “Additional Insured”:
 - 1. Profile Systems, LLC
 - 2. Project Customer

NOTE: Inspect the Profile P1900 Series System Unit components prior to installation for any damage which may have occurred during shipping. Report any damage to Profile Systems, LLC immediately.

Installation of Profile P1900 Series System Unit equipment presents potential unsafe conditions, including, but not limited to, electrical shock, improper voltage to components and improper operation that may cause personal injury or damage to property.

Installation of Profile Systems P1900 Series System Unit equipment must be performed by qualified electrical and mechanical contractors in good standing who are properly licensed to perform work in the municipality, county, and state where installation of Profile Systems P1900 Series System Unit equipment will occur. Installation practices should follow recommendations and procedures as determined by the original equipment manufacturer(s) and should adhere to the application and use of the equipment as intended by the original equipment manufacturer(s).

- C) Subcontractor will mount the provided P1900 Series System Unit in a manner that satisfies the following criteria:
 - 1. Unit is to be mounted in a plumb and level fashion using appropriate anchoring hardware near existing lighting electrical panel and/or contactors such that high voltage wiring and conduit requirements are minimized.
 - 2. Unit is to be mounted away from high traffic or commonly used work spaces.
Mount appropriate antenna. Making sure the connection is tight, and where applicable, any access cable is secured using zip ties and or any other acceptable securing devices. **At no time should the antenna or its mounting be connected to earth ground.** Weak communications signal may require the antenna to be mounted outside the facility. (See P1900 Series System Unit Wiring Overview Diagram)

D) Subcontractor will connect a 120VAC or 240VAC input power source to the P1900 Series System Unit. This power will always source from an independent breaker as feasible. Circuits of specified controlled loads (i.e. exterior lighting) will be energized by wiring the existing contactors to the proper positions on the termination strip of the P1900 Series System Unit. Refer to detailed Wiring Diagram #1a. For example, exterior lighting may be connected as follows when required:

- Circuit 1 (K1): Parking Lot Lights
- Circuit 2 (K2): Building Lights & Signage
- Circuit 3 (K3): Spare
- Circuit 4 (K4): Spare

The normally closed dry contacts of relays K1 thru K4 can be used with various loads. (Refer to detailed Wiring Diagram #1b) Contacts are rated as follows:

- 120 VAC @ 10 amps
- 240 VAC @ 5 amps
- 277 VAC @ 3 amps

NOTE: Subcontractor will ensure that only the correct loads/circuits are controlled by the P1900 Series System Unit per project requirements.

IMPORTANT: Profile Systems recommends using 18AWG stranded shielded Plenum 3 conductor cable for all sensor and thermostat connections (i.e. Carol Cable E20325 75° 300V PVC jacket or equivalent).

E) Subcontractor will mount the provided thermostats and remote room temperature sensors in a manner that satisfies the following criteria:

1. Thermostats are to be mounted upright in a plumb and level fashion using appropriate anchoring hardware in the same location as existing thermostats or other HVAC controls such that existing HVAC control wiring can be used whenever possible (**Refer to Detailed Wiring Diagram “2 Series” that follows**). Existing thermostats or other HVAC controls should be removed to allow for installation of new thermostats **provided that no significant physical damage to wall coverings occurs and no cosmetically unappealing evidence of alteration remains after installation is complete.** (Wall plates may be necessary to cover any exposed drywall or wall openings.)
2. If using remote room sensors, the thermostats are to be mounted near each other in the area where the main P1900 Series System Unit is mounted whenever possible such that communications wiring between thermostats and the main P1900 Series System Unit is minimized.
3. Wall mounted remote room temperature sensors are to be mounted in a plumb and level fashion in the same location as existing remote room temperature sensors such that existing sensor wiring can be used whenever possible (**Refer to detailed Wiring Diagram “3a” that follows**). Existing sensors should be removed to allow for installation of new sensors **provided that no significant physical damage to wall coverings occurs and no cosmetically unappealing evidence of alteration remains.** (Wall plates may be necessary to cover any exposed drywall or wall openings.)

4. If the existing thermostats or room sensors are physically in the wrong location, **the new thermostats or room sensors should be relocated to facilitate proper operation.** Examples of wrong locations are; but not limited to:
 - Two or more thermostats (not using remote sensors) mounted next to one another.
 - Near or above site equipment, wet areas such as sinks, or any location that may affect the temperature, humidity or operation of the thermostat/sensor.
 - On an outermost wall. **(If there is no feasible way of moving the thermostat off an exterior wall, then the space and opening behind the thermostat must be insulated, to prevent any air flow from affecting its temperature sensor).**
 - In direct contact with shelving or storage areas that obstruct proper airflow to the sensor.
 - Away from the space or area actually controlled by the thermostat.

F) Subcontractor will connect each HVAC Roof Top Unit (“RTU”) with its respective thermostat by installing new low voltage control wiring. Recommended wiring from RTU to thermostat is 8 conductor cables per the recommended Profile Systems specifications.

NOTE: Multi-splices and substandard wiring methods of cabling is not acceptable. If these conditions are pre-existing, new cabling for thermostat and/or sensors must be used.

The subcontractor must ensure that a direct connection exists between “Common” of the RTU and the -24V terminal on the thermostat (Earth ground cannot be used as a current carrying conductor). Refer to “Detailed Wiring Diagram #2 Series”.

1. Properly terminate all applicable thermostat connections to the RTU low voltage terminal strip via manufacturer recommended Plenum cable.
2. Install the supplied Discharge (Supply) Air Sensor within each respective RTU's supply air duct, ensuring that it is downstream of both the Evaporator coil and the Heat Exchanger or Electric Furnace, and wire it to the “T2” thermostat input, making sure to check dipswitch settings per the manufacturer’s installation manual. Refer to “Detailed Wiring Diagram #2 Series”.
3. When applicable, install the supplied Remote Room Temperature Sensor in the conditioned space. Wire it to the “T1” input on the corresponding thermostat, making sure to check dipswitch settings per the manufacturer’s installation manual. Refer to “Detailed Wiring Diagram #2 Series”.
4. Connect the RS485 communications bus of the thermostats in daisy-chain fashion (“A” to “A”, “B” to “B”, “Ref” to “Ref”, “Shield” to “Shield”) terminating the communications wiring at the “A”-“B”-“Ref” input on the unit. **Never use wire from the communications cable for the RTU low voltage connections. Likewise, never use wire from the low voltage RTU cable for communication connections.**
5. The stranded shield wires from the communication cables at each thermostat need to be connected and twisted together also in a daisy-chain fashion. **They also must to be properly insulated from any contact with other wires or ground.**

G) Subcontractor will install temperature sensor probes in selected refrigeration units for refrigeration monitoring:

1. Install the supplied temperature sensor probes within each refrigeration unit **behind** the evaporator fan and near the ceiling in such a way that the probes are protected from stocking shelve areas or other hazards. Refrigeration unit penetrations should be of minimal diameter and must be properly sealed (i.e. silicon-filled) after probes are installed. Insulate shield wire from all other connections. **Red, Black and White wire connections should NEVER be allowed to short to any metal surface.**

2. Wire the temperature probes back to the appropriate inputs on the P1900 Series System Unit unit using 3 conductor shielded cable per recommended Profile Systems specifications. Refer to “Detailed Wiring Diagram #3b”.
- H) Subcontractor will adhere to the following additional general guidelines during installation of the Profile P1900 Series System Unit:
1. **All high voltage wiring must be contained inside conduit in compliance with all applicable codes, both local and national.**
 2. The RS485 communications wiring installed by subcontractor is to be 3 conductor shielded cable per the recommended Profile Systems specifications.
 3. All low voltage control wiring, sensor wiring, and communications wiring inside the facility must be run inside walls and above ceilings such that visibility is minimized. Care must be taken to minimize any potential damage to the outer insulation jacket of the wire.
 4. Wiring to rooftop units that is exposed outside of the facility (i.e. outdoors) **must be run inside UV resistant protective rigid or flexible tubing** to prevent exposure to the elements.
 5. **Subcontractor is responsible for repair of any damage to wall and/or ceiling coverings that occurs during installation.** Affected wall and ceiling areas must maintain a cosmetically appealing appearance equal or superior to the cosmetic condition that existed prior to installation work by the subcontractor. Subcontractor may be required to install cover plates or other common fittings or coverings to conceal affected areas such that no visually unappealing evidence of alteration remains after installation is complete. **All wiring and/or conduit extending up to and through ceiling tiles or other ceiling material must be neatly and professionally cut into the ceiling material and the ceiling material properly replaced such that the affected area is left in a cosmetically appealing manner.**
 6. Subcontractor will be responsible for disposing of all debris created as a result of their work and will clean all affected working areas of scrap, debris, dust, etc resulting from installation work.
 7. Unless instructed otherwise, the subcontractor will collect and neatly box all previous controls and associated components that were removed and replaced with the P1900 Series System Unit. Unless otherwise instructed, the previously removed equipment should be left in the possession of the facility manager or representative prior to leaving the job site.
 8. **Subcontractor will return any/all damaged and/or unused Profile System parts to Profile Systems within 10 business days. All items must be labeled with appropriate Return Material Authorization (“RMA”) number(s) noting jobsite and issue(s). Failure to return such items in a timely manner may result in the subcontractor being charged for those items.**
- I) Subcontractor will perform the required P1900 Series System Unit commissioning tasks via telephone with Profile System Customer/Technical Support staff, as outlined in Appendix B – P1900 Series System Unit Commissioning. Subcontractor will complete and fax installation documentation as called for in Appendix C and Appendix D to Profile Systems at (219) 757-3541, Attention: Customer Support
1. P1900 Series System Unit Pre-Installation Report
 2. P1900 Series System Unit Post Installation Checklist
- J) All questions regarding this Scope of Work & Installation Guidelines should be addressed to Profile Systems, LLC and the **specified Profile Systems Project Manager: (219-757-3575/800-898-5483)**

APPENDIX A - INSTALLATION DIAGRAMS

P1945 System Wiring Overview

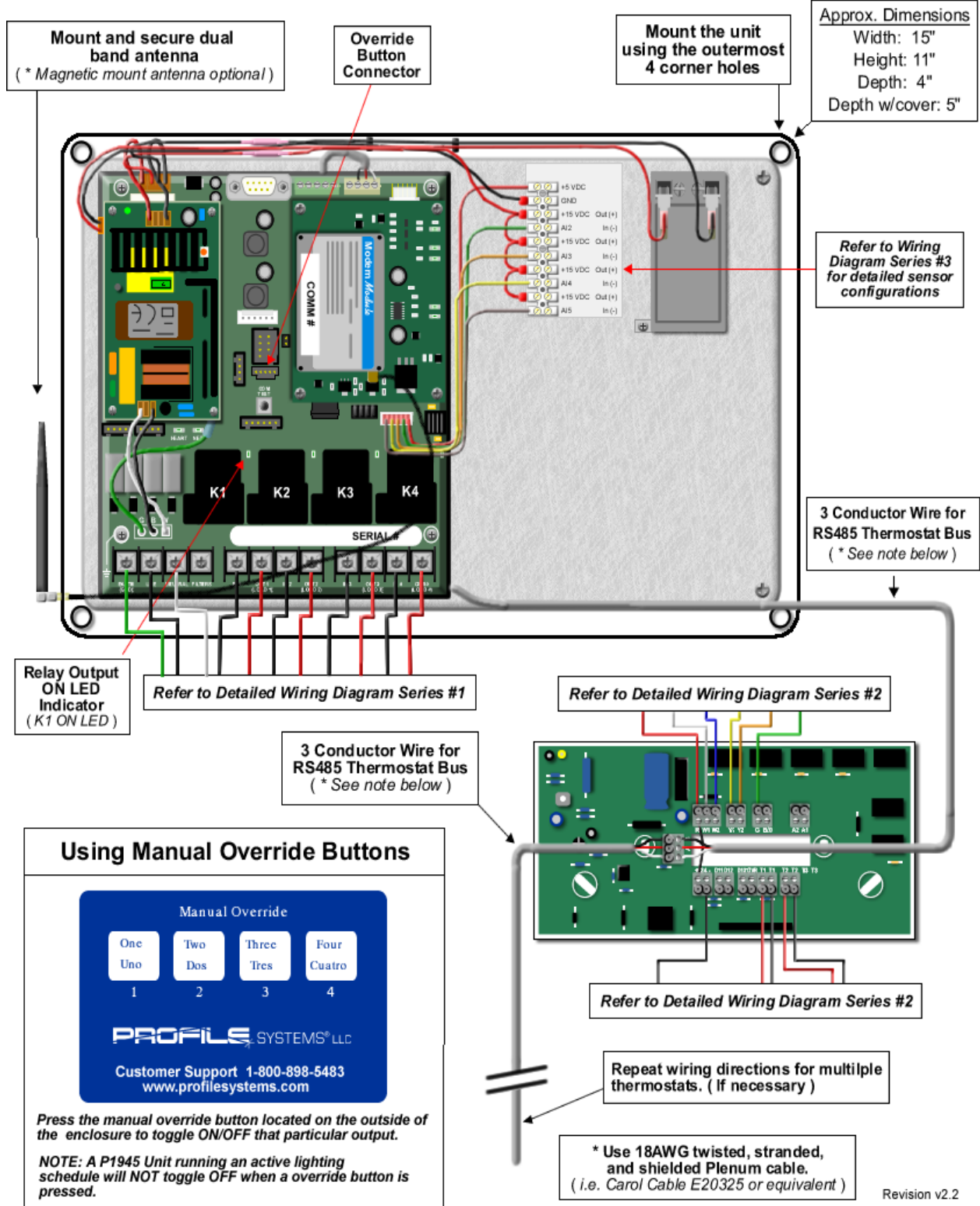

Detailed Wiring Diagram #1b

(Sample Wiring Diagram)

Sample Wiring Diagram

120VAC Source - Dry Contact Relays Fed with Various Voltages for Different Contactor Coil Voltages

Main Unit Output Connections
Normally Closed Dry Contact
Relays (K1 - K4)

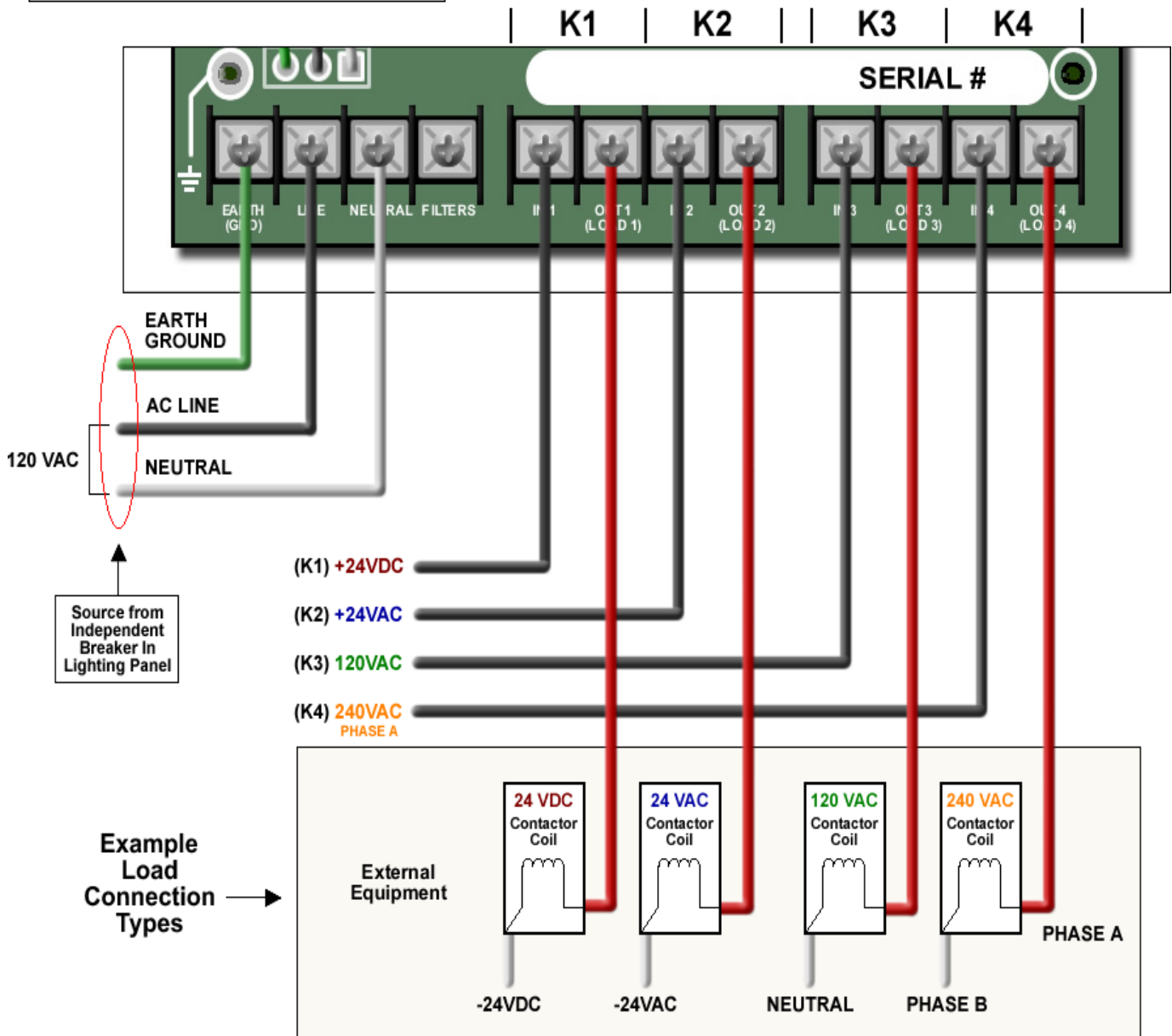

* Make sure to use appropriate wire gauge when connecting to external equipment.

Revision v1.0

Detailed Wiring Diagram #2a

(Thermostat Connections)

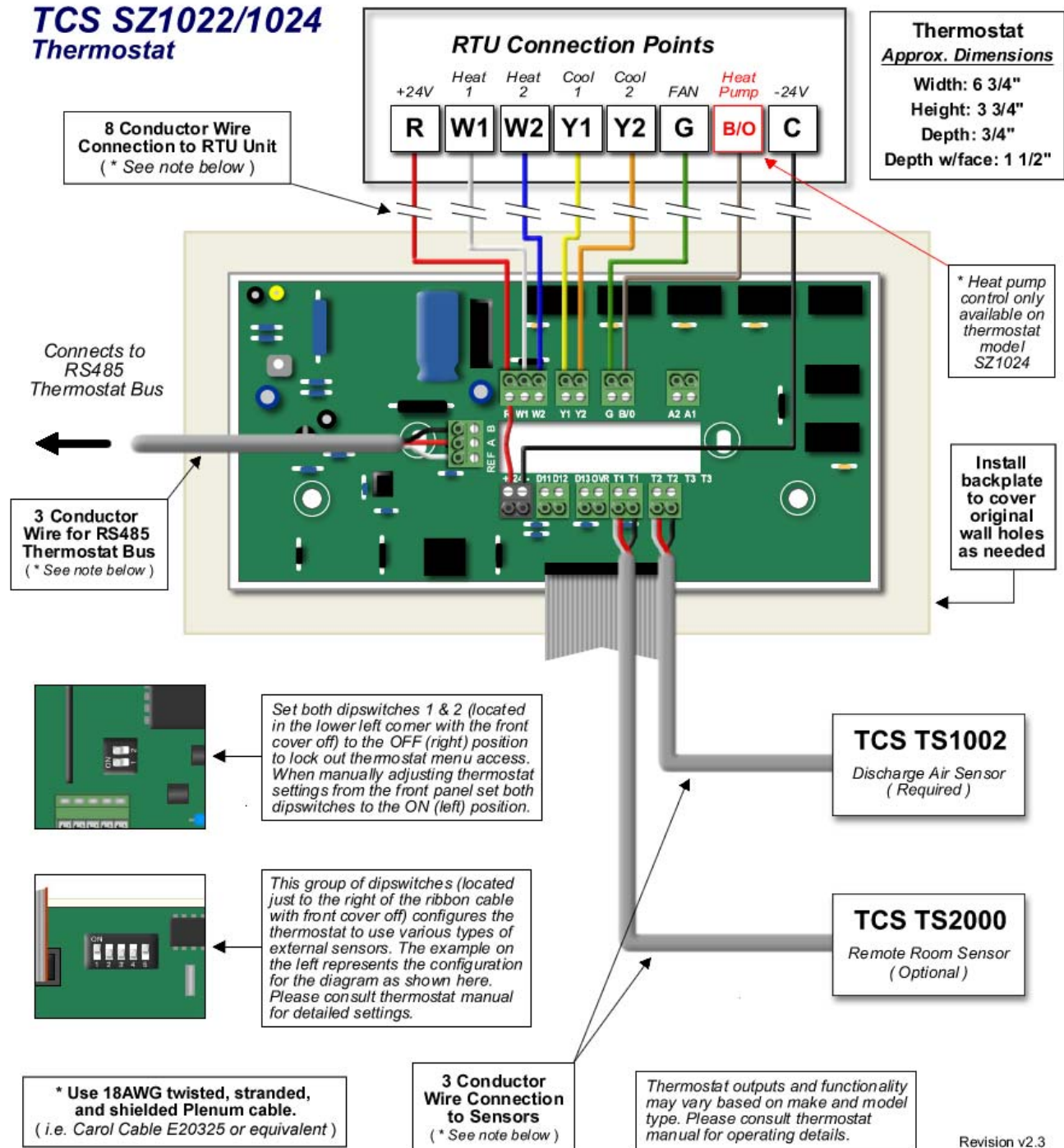

Detailed Wiring Diagram #3a

(Remote Sensor Connections)

Typical remote room temperature sensor connection diagram:

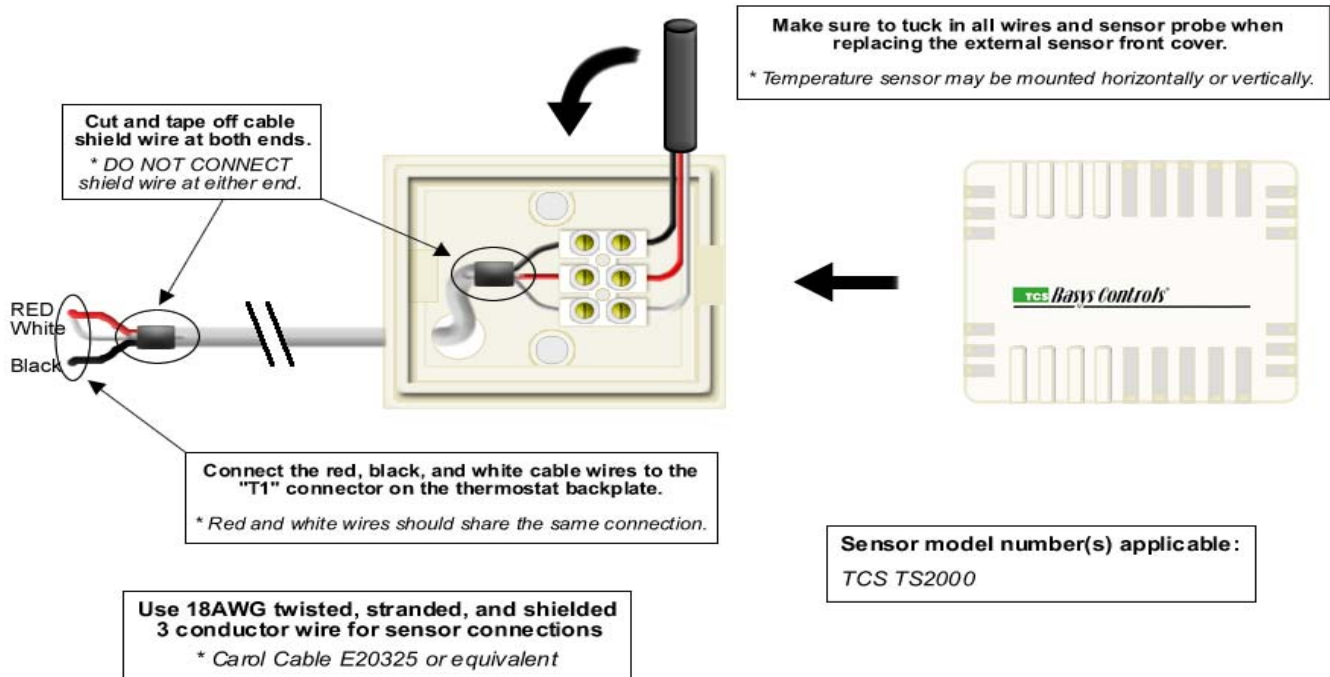

Typical discharge / return temperature sensor connection diagram:

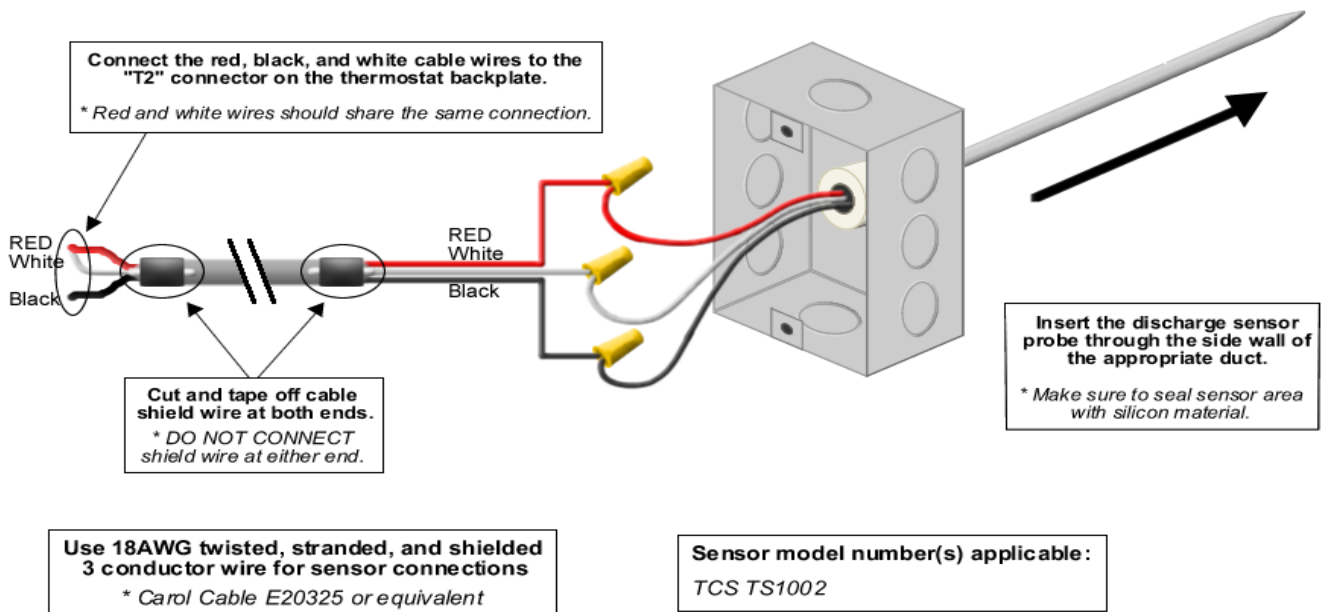

Revision v2.2

Detailed Wiring Diagram #3b

(Cooler/Freezer Temperature Probe V2 Connections)

Typical 4-20mA Profile Systems V2 temperature sensor connection diagram:

Connected as analog input (Configured for input AI2 as pictured)

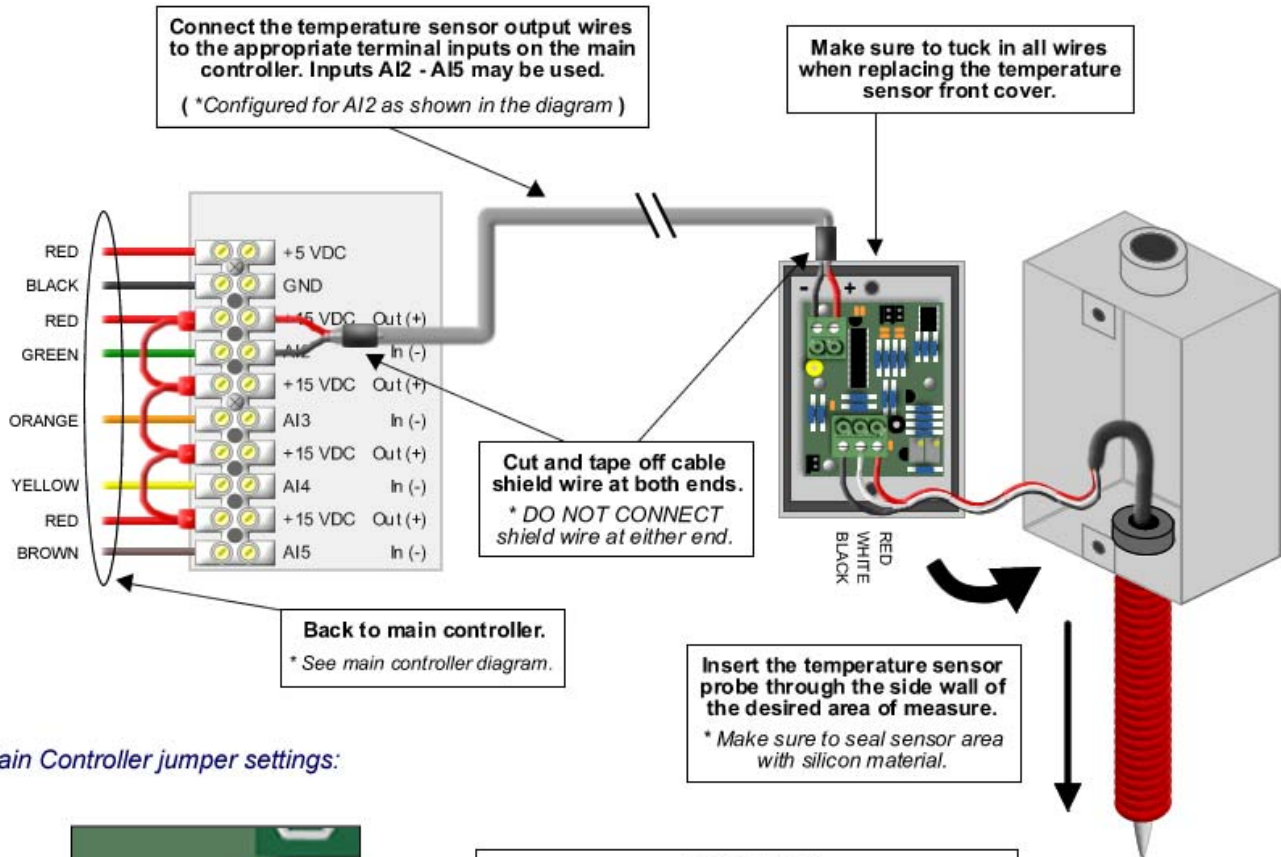

Main Controller jumper settings:

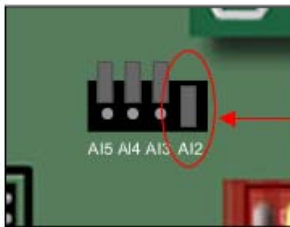

IMPORTANT
Make sure the appropriate jumper(s), located at the main controller, are in the ON position for each 4-20 mA transmitter in use. Multiple jumpers may be enabled dependent upon sensors used.
(*Configured for AI2 as shown in the diagram)

Use 18AWG twisted, stranded, and shielded 3 conductor wire for all sensor connections.
* Carol Cable E20325 or equivalent

Device model number(s) applicable:
Profile Systems Temperature Sensor Assembly V2 or equivalent

Revision v1.4

Detailed Wiring Diagram #3d

(Temperature/Humidity Sensor Connections)

Typical 4-20mA Minco temperature/humidity sensor connection diagram:

Connected as analog inputs (Configured for inputs AI2 & AI3 as pictured)

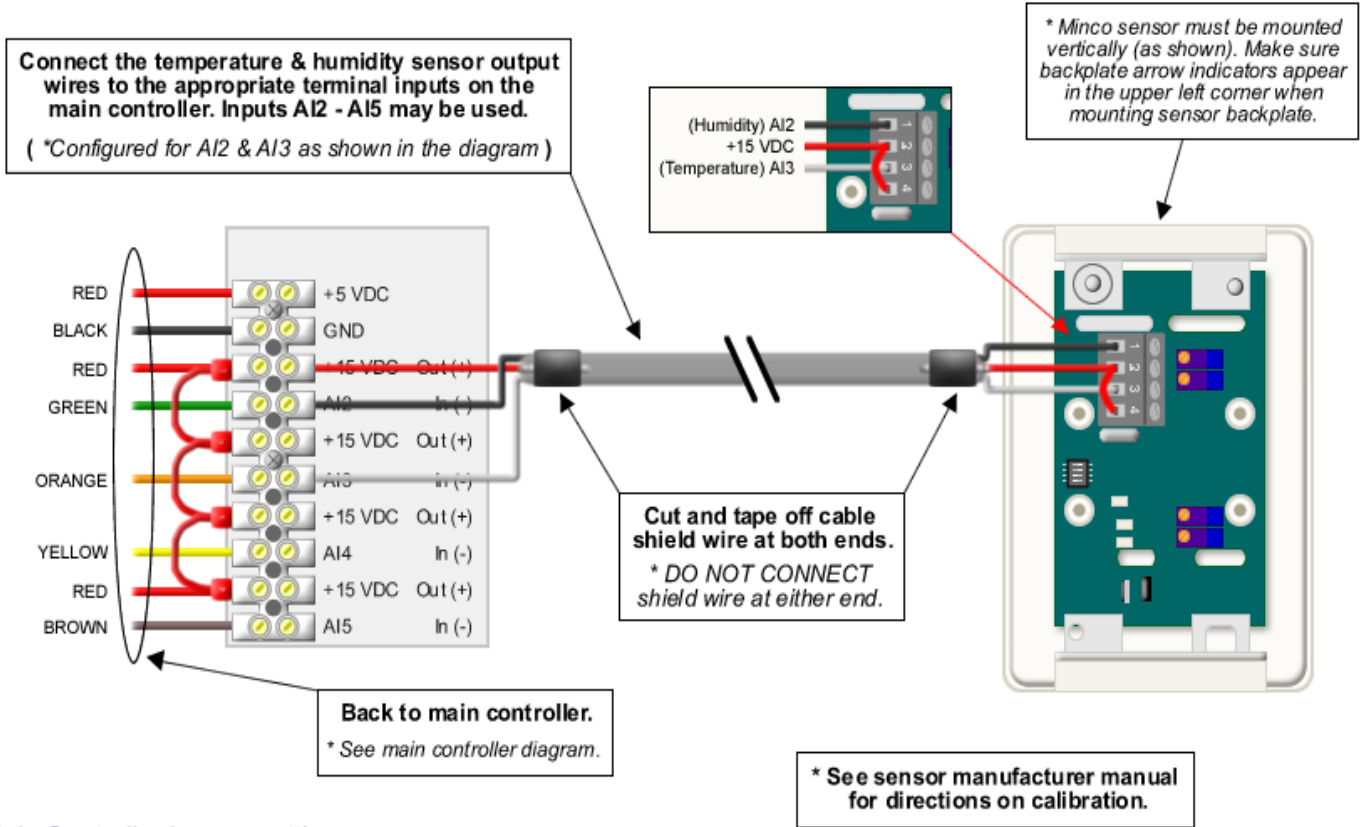

Main Controller jumper settings:

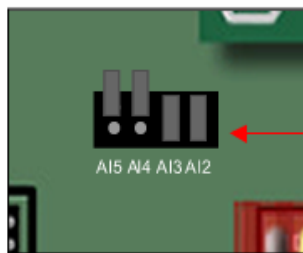

IMPORTANT
Make sure the appropriate jumper(s), located at the main controller, are in the ON position for each ANALOG input in use. Multiple jumpers may be enabled dependent upon sensors used.
(*Configured for AI2 & AI3 as shown in the diagram)

Use 18AWG twisted, stranded, and shielded 3 conductor wire for all sensor connections.
* Carol Cable E20325 or equivalent

Device model number(s) applicable:
Minco HT2S1H or equivalent

Detailed Wiring Diagram #3e

(Lumen Sensor Connections)

Typical 0-5VDC Lumen sensor connection diagram:

Connected as digital input (Configured for input AI3 as pictured)

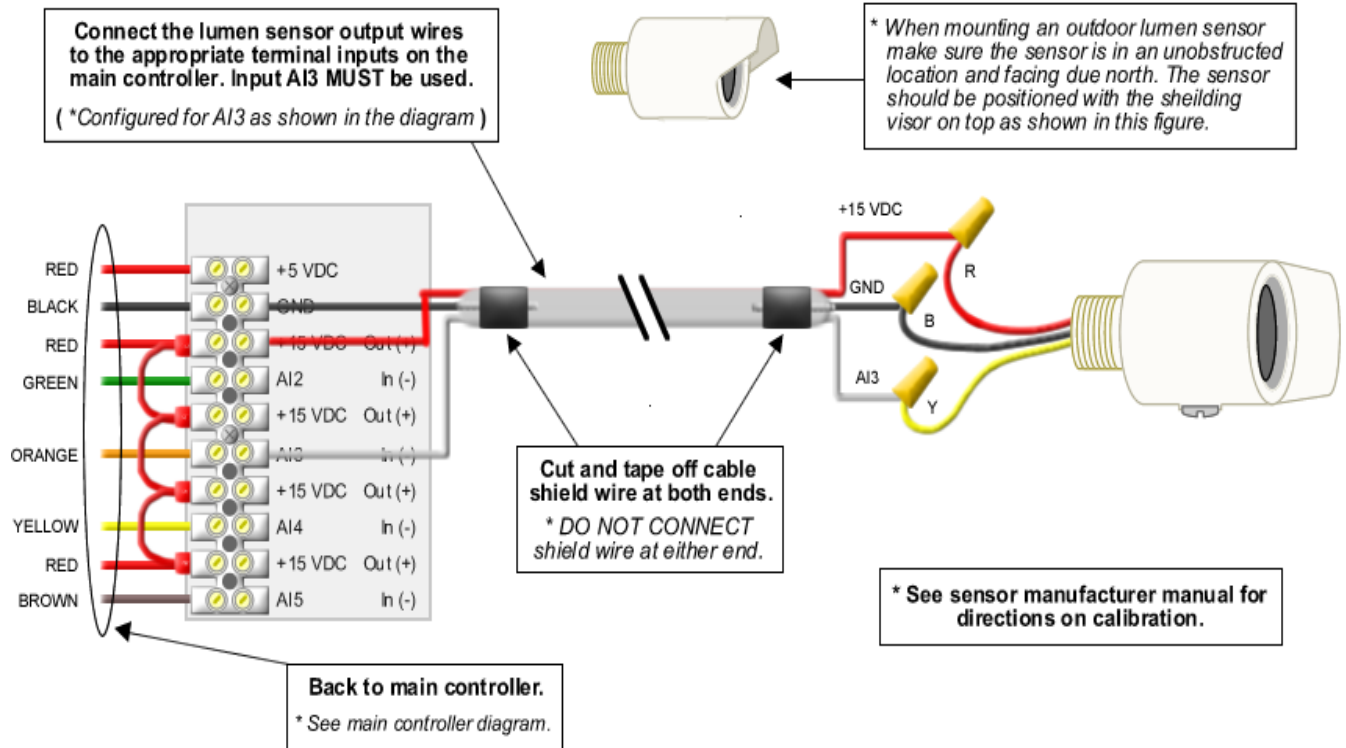

Main Controller jumper settings:

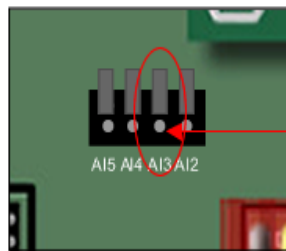

IMPORTANT
Make sure the appropriate jumper(s), located at the main controller, are in the OFF position for each ANALOG input in use. Multiple jumpers may be enabled dependent upon sensors used.
(*Configured for AI3 [digital] as shown in the diagram)

Use 18AWG twisted, stranded, and shielded 3 conductor wire for all sensor connections.
* Carol Cable E20325 or equivalent

Device model number(s) applicable:
PLC Multipoint MK7-B-CR-0/5 (pictured)
PLC Multipoint MK7-B-CS-0/5 (skylight)
PLC Multipoint MK7-B-CCF-0/5 (indoor)
or equivalent.

Detailed Wiring Diagram #3f

(Dry Contact Sensor Connections)

Typical Dry Contact Sensor connection diagram:

Connected as digital input (Configured for input AI2 as pictured)

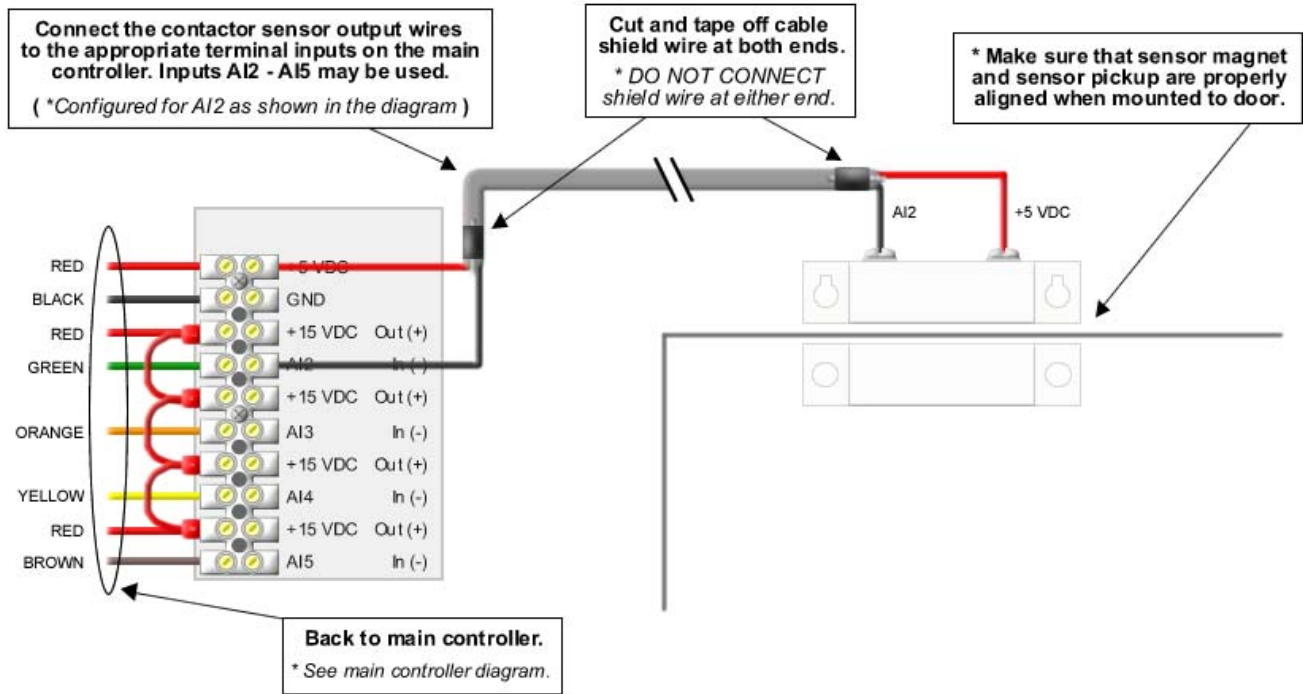

Main Controller jumper settings:

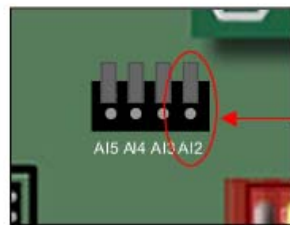

IMPORTANT
Make sure the appropriate jumper(s), located at the main controller, are in the OFF position for each ANALOG input in use. Multiple jumpers may be enabled dependent upon sensors used.
(* Configured for AI2 [digital] as shown in the diagram)

Use 18AWG twisted, stranded, and shielded 3 conductor wire for all sensor connections.
* Carol Cable E20325 or equivalent

Device model number(s) applicable:
Honeywell 7939WG-WH or equivalent

Revision v1.2

APPENDIX B – P1900 SERIES SYSTEM UNIT COMMISSIONING

The following procedural steps are necessary to properly commission a Profile Systems P1900 Series System Unit installation and verify the operational status of the system. Failure to complete ANY of these steps during installation will result in a non-commissioned P1900 Series System Unit.

**PROFILE SYSTEMS, LLC WILL NOT REMIT
PAYMENT FOR INSTALLATION SERVICES ON
P1900 SERIES SYSTEM UNIT INSTALLATIONS
THAT ARE NOT PROPERLY COMMISSIONED!**

Profile Systems, LLC will not be held responsible for installation charges or service calls to an installation site for commissioning tasks that should have been performed during the initial installation.

Installation and commissioning of the Profile P1900 Series System Unit will require only standard electrical and mechanical work. No device programming by the field installer will be required. All P1900 Series System Unit components are pre-programmed and any adjustments to programming will be performed wirelessly and remotely by Profile Systems Customer/Technical Support.

Profile P1900 Series System Unit Commissioning Procedure

Step 1:

Begin by filling out the P1900 Series System Unit Installation Report.

Step 2:

After mounting and powering the P1900 Series System Unit **and** antenna, locate the LED labeled "NET" on the P1900 Series Systems Unit and note its status (i.e., lit, not lit, or blinking). Then call Profile Customer/Technical Support at **800-898-5483**. Indicate that you are calling for initial system commissioning verification and provide the Customer Support Representative (CSR) with your name, your company, the installation location, the serial number of the P1900 Series System Unit, and the "NET" LED status.

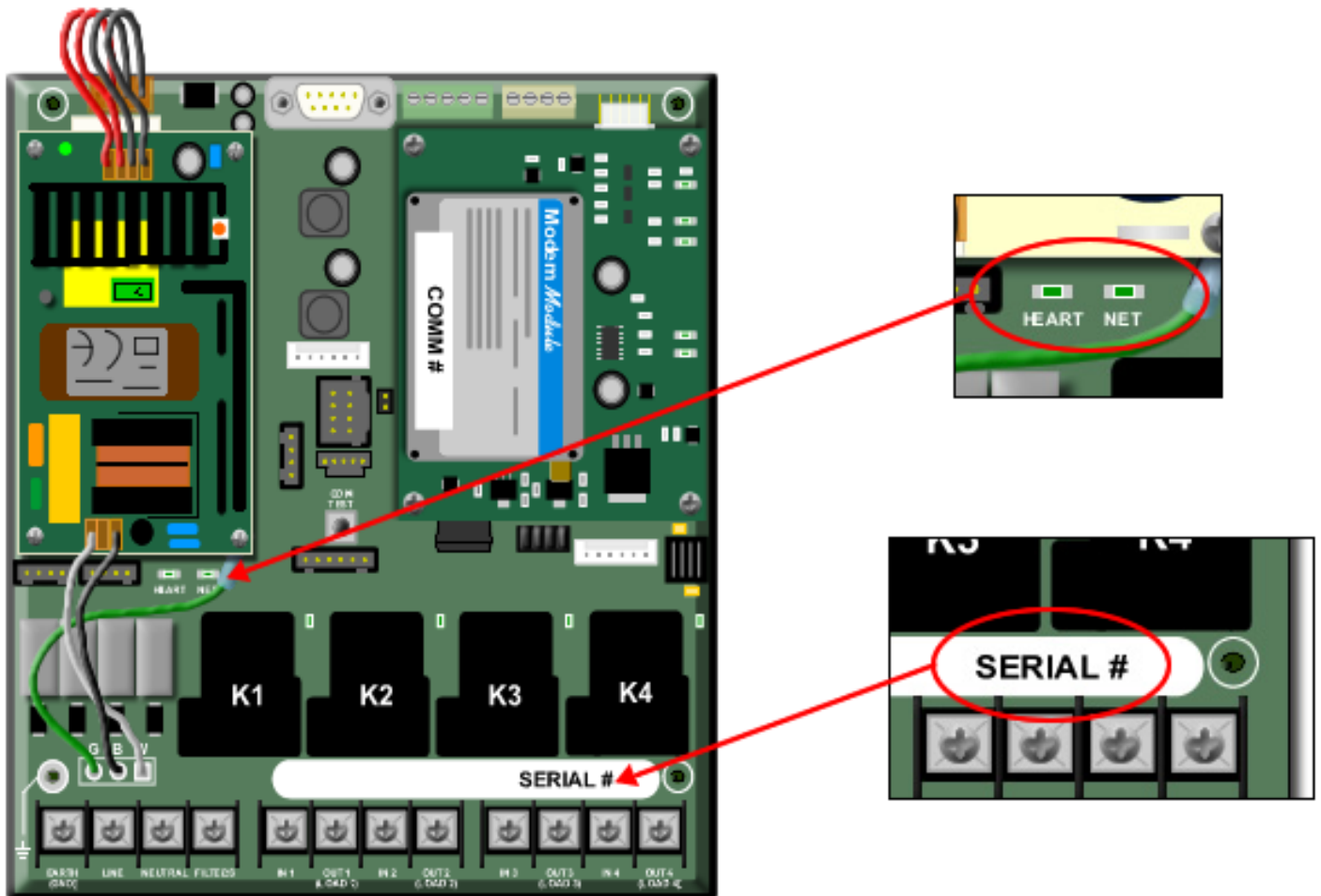

The Profile CSR will perform a test to confirm that communications with the P1900 Series System Unit has been established and begin the commissioning process.

Step 3:

Perform the electrical and mechanical installation tasks required to complete installation of the P1900 Series System Unit and associated component devices. During this process, verification of thermostat and/or sensor operation should be performed once they are connected. (This requires the use of a portable/handheld temperature monitoring device). Also, verification of thermostat wiring to RTU's will be performed following verbal instructions given by Profile Systems.

Step 4:

When all electrical and mechanical installation tasks are complete, call Profile Customer/ Technical Support at **800-898-5483**. Again, provide the Customer Support Representative (CSR) with your name, your company, the installation location, and indicate that you are calling for final commissioning. With the participation of the installer, a Profile Systems CSR will proceed through a series of system checks and verification tests to ensure that the entire P1900 Series System Unit is functioning properly. Upon completion of this final step, the Profile Systems CSR will endorse the commissioning of the P1900 Series System Unit. NOTE: Participation of the subcontractor will be required.

NOTE: System verification is a vital step in the commissioning process. The installing contractor needs to allocate time at the end of the installation for this process. Unless instructed by Profile Systems, finalizing an installation prior to performing the verification process will leave the installer/contractor responsible for the cost to revisit the location and properly finish the commissioning process.

Step 5 (Final):

Promptly complete the P1900 Series System Unit Installation Report and the P1900 Series System Unit Installation Checklist. Fax both documents to 219-757-3541 Attention: Customer Support. Retain the original copy for your files.

NOTE: Failing to provide these documents will delay payment for subcontractor services.

Post-Installation Inspection Report

This report outlines the activities that need to be performed by the installer/contractor once installation is complete. This is to be completed before and/or during the commissioning of a site. As a result of this inspection, any issues that are found at the site will need to be corrected by the contractor. This Post Installation document is to be **FILLED OUT COMPLETELY** and then **SIGNED** by the installer/contractor. In addition to this document, the contractor will be expected to call CS (Customer Support) to verify and ensure the equipment is working properly.

P1900 Series System Unit

- Picture of the P1900 Series System Unit and the antenna with the cover off the unit from a distance.
- Close up picture of the P1900 Series System Unit so that internal wiring can be identified.
- Picture of the lighting panel / circuit breaker from which the unit is fed.
- The correct wire size and color is used for the over-current protection (OCP) device provided on both the P1900 input circuit and the lighting contactors.
 - Wire gauge size _____ on _____ amp breaker
 - Relay load circuit on _____ amp breaker
- The P1900 Series System Unit receives power from a dedicated circuit that is properly labeled.
- A “bonded” Earth Ground is run from the lighting panel to the P1900 Series System Unit and tested with DMM.
- The low voltage and high voltage wiring is not run in the same conduit.
- No debris is left in or on the P1900 Series System Unit.
- The antenna cable connection is tight.
- All wires are neatly dressed and properly terminated with electrical tape.
- AC circuits and wiring are installed in proper conduit that meets all applicable codes.
- Using manual Override buttons provided on the cover of the P1900 Series System Unit, energize one circuit at a time and re-verify which lights are being controlled by that circuit. (Using the membrane switch deactivate each circuit individually before testing the next circuit in the sequence.)

Thermostats

- Photo of each thermostat from a distance to show location. (Label each sensor photograph to designate which RTU it is monitoring).
- Photo of each thermostat close up with the cover on and cover off to show wiring and connections. (Label each sensor photograph to designate which RTU it is monitoring).
- Photo of each of the remote room sensors if applicable. (Label each sensor photograph to designate which RTU it is monitoring).
- Photo of each installed duct sensor. (Label each sensor photograph to designate which RTU it is monitoring).
- Photo of how the thermostat wiring was terminated within each RTU. (Label each sensor photograph to designate which RTU it is monitoring).
- All thermostats / sensors are in the proper locations.

- The shield in the communication wire is tied together at each thermostat, fully insulated from any other conductor or ground and then terminated to Earth Ground at the P1900 Series System Unit.
- None of the thermostats are mounted or located incorrectly. The Thermostats DIP switches are set correctly according to the application used. Addresses per location were re-verified.
- Proper wiring is installed or utilized to activate all cooling and heating stages for each RTU.
- Multiple stages of cooling or multiple stages of heating are not be jumpered together.
- Any wiring to rooftop units is not exposed to the elements (i.e. outdoors) and is run inside UV resistant protective, rigid or flexible tubing to prevent exposure damage.
- Duct sensor locations have been verified by the cooling and heating operation of the RTU while measuring the duct temperature with a calibrated external handheld device.

Temperature Probes

- Picture of each installed probe on both sides of penetration into the refrigeration unit.
- The supplied temperature probes are within each refrigeration unit (walk-in cooler, walk-in freezer) behind the evaporator fan and near the ceiling such that the probes are protected from stocking shelve areas.
- The penetration holes are properly sealed with a compound that meets both temperature and environmental specifications.
- Besides the connection of the probes themselves; there are no other splices in the probe cable wiring.
- Red, Black and White wire connections along with the shield are properly insulated so that they do not make contact with any other conductors or Earth Ground.
- Location of probe in each refrigeration unit is re-verified with a calibrated external handheld device.

Comments

“I hereby establish that I have fulfilled the items above to the best of my ability and everything that I have “checked off” affirms it is true and accurate.”

Installer/Contractor SIGNATURE: _____

Installer/Contractor: Company Name: _____

Name/Title: _____

Date: _____

Please fax completed form to Profile Systems at 219-757-3541.

Intentionally Left Blank